



Emergency Engine and Turbine Requirements

Document Number:
EHS-ENMG-SOP.01 Rev.4
Effective Date: July 14, 2014
Revision Date: July 14, 2019

1.0 Purpose and Applicability

- 1.1 The purpose of these guidelines is to identify the processes and requirements that must be followed to ensure compliance with the Massachusetts Department of Environmental Protection Emergency Engine and Turbine Compliance Certification Requirements.
- 1.2 These guidelines apply to **emergency engines** with a **rated power output equal to or greater than 37 kW and less than one MW** that have been installed after March 23, 2006, on the University of Massachusetts Amherst campus or its satellite facilities.

2.0 Definitions

- 2.1 **Adjacent Structure** – A structure that is within 5L of the stack. 5L means five times the lesser dimension (height or maximum horizontal width) of the structure.
- 2.2 **Compliance Certification** – Certification form that poses a series of questions to ensure that the new emergency engine and emergency turbines comply with the new Environmental Results Program (ERP) Certification Standards.
- 2.3 **Emergency** – An electric power outage due to failure of the grid (in whole or in part), on-site disaster, local equipment failure, flood, fire, or natural disaster.
- 2.4 **Emergency or Standby Engine** - for the purposes of 310 CMR 7.02(8)(i) and 7.03(10), means any stationary internal combustion engine which operates as an emergency or standby mechanical or electrical power source. A load shaving unit, peaking power production unit or a standby engine in an energy assistance program is not an emergency or standby engine under this definition
- 2.4 **Initial Compliance Certification** - An initial compliance certification form that must be completed for each new emergency engine or emergency turbine within 60 days of starting operation.
- 2.5 **Engines** – Spark ignition and compression ignition stationary reciprocating internal combustion engines.
- 2.6 **NAAQS (National Ambient Air Quality Standards)** – Massachusetts is subject to national standards that deal with six criteria pollutants: particulate matter (PM), nitrogen oxides (NOx), sulfur dioxide (SO₂), ozone, carbon monoxide (CO), and lead.
- 2.7 **Rated Power Output** – The maximum electrical or equivalent mechanical power output stated on the nameplate affixed to the engine or turbine by the manufacturer.



Emergency Engine and Turbine Requirements

Document Number:
EHS-ENMG-SOP.01 Rev.4
Effective Date: July 14, 2014
Revision Date: July 14, 2019

- 2.8 **Return to Compliance Plan** – A form that requires the owner/operator to explain the compliance problem, list the correction actions to be taken, and provide an anticipated return to compliance date.
- 2.9 **Source Registration/Emission Statement** – Any person who operates a new emergency engine and emergency turbine subject to this ERP program is required to submit a Source Registration and Emission Statement, including BWP AQ AP-1 form to MA DEP.
- 2.10 **Supplier** – A person who manufactures, assembles, or otherwise supplies engines or turbines.
- 2.11 **Turbine** – A stationary combustion turbine.

3.0 Roles and Responsibilities

- 3.1 **Environmental Health & Safety** – EH&S is responsible for coordinating the documentation and reporting process to ensure compliance with the MA DEP regulations regarding the installation of new emergency and non-emergency engines and turbines.
- 3.2 **Physical Plant** – Physical Plant is responsible for the upkeep, maintenance, and inspection of all emergency and non-emergency engines or turbines on the UMass Amherst campus.
- 3.3 **Facilities Planning or Other** – the UMass department that is responsible for the procurement and placement of an emergency or non-emergency engine or turbine is responsible that the unit and its placement complies with this protocol and applicable regulations.
- 3.3 **Engine or Turbine Operator** – The “hands-on” person who has the daily responsibilities of operating and maintaining the emergency engine unit properly.
- 3.4 **Engine or Turbine Owner** – Should obtain from engine supplier a completed Emission Limit Certification Form certifying that the engine or turbine as designed and installed complies with the applicable emission limits.

4.0 Procedure

4.1 Purchasing

- 4.1.1 The department that purchases an emergency engine or turbine must ensure that the unit conforms to UMass Amherst specifications and complies with the applicable emission and noise standards.



Emergency Engine and Turbine Requirements

Document Number:
EHS-ENMG-SOP.01 Rev.4
Effective Date: July 14, 2014
Revision Date: July 14, 2019

- 4.1.2 **Non-turn back hour counter:** Each unit must be equipped with a non-turnback hour counter that is operated and maintained in good working order. The counter should have the ability to count in minutes.
- 4.1.3 **Provisions for load bank testing:** One additional circuit breaker should be installed for load bank test rated to 100% of Generator maximum output. Generators over 300 KW should be equipped with built in load banks.
- 4.1.4 **Monitoring:** Generator should be equipped with provisions to monitor two trouble points tied to building monitoring system.
 - 4.1.4.1 Generator running
 - 4.1.4.2 Generator trouble
- 4.1.5 **Fuel Meter:** Each unit must be equipped with a fuel meter. The fuel meter should read to the tenth of a gallon, not gallon. Meters should also be able to output a 4 to 20 milliamp signal for Metysys connections (if needed).
- 4.1.6 **Automatic Transfer Switch:** Should have compatible software with the Generator, GEN SET
- 4.1.7 **Color:** Units that are installed in an open air environment should be green or have a green shell. The color of indoor units is irrelevant.
- 4.1.8 **EPA Certification:** Emergency engines burning fuel oil or natural gas must conform to the EPA's non-road engine requirements and must be confirmed by the supplier.
 - 4.1.8.1 The supplier must provide a copy of the Certificate of Conformity issued by the Administrator of the EPA pursuant to 40 CFR 89.105, as in effect October 23, 1998, for the applicable emission limitations at the time of installation. The unit must also be capable of demonstrating compliance with the emission limitations for the first three years of operation.
- 4.1.9 **Emissions:** All emergency turbines must meet the emission limitations for NOx (See 4.1.5).
- 4.1.10 **Fuel Storage:** If the unit is powered by fuel oil and requires a tank equal to or greater than 55 gallons, the tank shall be double walled. Tanks should be compliant with industry standards such as American Petroleum Institute (API), American Society of Mechanical Engineers (ASME), Steel Tank Institute (STI), and/or Underwriter's Laboratory.



Emergency Engine and Turbine Requirements

Document Number:
EHS-ENMG-SOP.01 Rev.4
Effective Date: July 14, 2014
Revision Date: July 14, 2019

4.2 Installation of Emergency Engines or Turbines

- 4.2.1 Units must be located in places that avoid exhaust impacts upon people, windows and doors that open, fresh air intake, and other sensitive receptors. See **Appendix A Stack Location and Design** which prioritizes stack location and design options when citing a unit.
- 4.2.2 The stack design must insure that the stack discharges vertically upward. Devices such as shanty caps and egg beaters are prohibited.
- 4.2.3 Units rated less than 300 KW shall have a minimum stack height of **five (5) feet**.
- 4.2.4 Units rated at 300 KW, but less than one MW, shall have a minimum stack height of **ten (10) feet** above the facility roof top or unit enclosure, whichever is lower.
- 4.2.5 For units rated at one MW and above, the minimum stack height must be 1.5 times the height of the building on which the stack is located.
 - 4.2.5.1 If the stack is less than 1.5 times the height of the building, or if any adjacent structures are taller than the stack, air quality modeling must be performed to document that the National Ambient Air Quality Standards will not be exceeded.
- 4.2.6 Units should be housed in enclosures specifically designed to attenuate sound.
 - 4.2.6.1 MA DEP considers a noise source to be violating its noise regulation if the source:
 - 1) Increases the broadband sound level by more than 10dB(A) above ambient, or
 - 2) Produces a “pure tone” condition – when any octave band center frequency sound pressure level exceeds the two adjacent center frequency sound pressure levels by 3 decibels or more. (Contact EH&S, for more information or assistance.)
- 4.2.7 The generator set should comply with building code NFPA 110 paragraph 7.13.4.3 A two hour full load test must be performed on site as part of the commissioning for any Emergency or Standby system. Documents must be forwarded with this application and to the building maintenance generator department.
- 4.2.8 If the unit requires a fuel oil storage tank, it shall be installed so that the space between the bottom of the tank and the floor allows for the visual inspection of leaks.



Emergency Engine and Turbine Requirements

Document Number:
EHS-ENMG-SOP.01 Rev.4
Effective Date: July 14, 2014
Revision Date: July 14, 2019

4.2.9 The department responsible for installing the unit shall complete the Emergency or Non-Emergency Engine or Turbine Form no later than one week after installation and send copies to:

4.2.9.1 **EH&S** Dennis Gagnon (dgagnon@ehs.umass.edu) or Terri Wolejko twolejko@ehs.umass.edu

4.2.9.2 **Physical Plant** Jim Antonovitch fish442@facil.umass.edu

4.3 Installation of Non-Emergency Engines or Turbines

4.3.1 The installation of non-emergency engine or turbine has different requirement than those outline in this protocol. Where these units are being considered this effort must be coordinated with EH&S and Physical Plant.

4.3.2 Information on the applicable requirements can be found at the following site: MA DEP Engine and Turbine Environmental Certification Workbook (non-Emergency – <http://www.mass.gov/dep/service/online/newkbook.doc>)

4.4 Engine or Turbine Emissions

4.4.1 Visible emissions from the engine or turbine may not exceed 20% opacity at any time during operation.

4.5 Operation and Maintenance

4.5.1 Environmental Management

4.5.1.1 If the unit utilizes fuel oil and has a storage tank capacity equal to or greater than 55 gallons, EH&S shall add the unit to the campus Integrated Contingency Plan. Associated procedures and forms shall be modified accordingly.

4.5.1.2 EH&S shall add the unit to the campus Air Operating Permit (Title V).

4.5.1.3 The unit will be inspected on a monthly basis by Physical Plant using the PP Tank and Generator Form. The completed form is returned to a PP Clerk who in turn enters the information into Tririga. Contained within the form are: SPCC information (if applicable), generator run-time, and fuel throughput.

4.5.1.4 EH&S monitors the generator run-time to ensure that the 300 hour annual limit is not exceeded.



Emergency Engine and Turbine Requirements

Document Number: EHS-ENMG-SOP.01 Rev.4
Effective Date: July 14, 2014
Revision Date: July 14, 2019

4.5.1.5 On or after July 1, 2007, no deliveries of fuel oil shall be accepted for burning in a unit that does not conform to EPA's sulfur limits for transportation distillate fuel (15 ppm sulfur).

4.5.1.6 EH&S will compile the necessary information, provided by the installing department, and complete the MA DEP Compliance Certification Form for submittal within 60 days of the initial operation of the engine or turbine. EH&S will add the information to Enviance for record storage.

A. The EHS Director is the designated Signatory Authority and will sign off on the MA DEP forms prior to submittal.

4.5.1.7 Should the unit fail to meet the minimum requirements outlined by the MA DEP Environmental Results Program, EHS will initiate steps (as required by MA DEP) to "Return to Compliance."

4.5.2 Administrative

4.5.2.1 The Physical Plant Tririga Asset Manager will assign the unit an asset number and add it to the preventative maintenance system.

4.5.2.2 The department responsible for the installation of the unit shall send the PP Asset Manager the unit's operations and maintenance manual.

4.5.3 Records and Documentation Requirements

4.5.3.1 Information on the equipment type, make, model, and rated power output must be kept on-site for the life of the ERP emergency or non-emergency engine or turbine.

4.5.3.2 If applicable, the results of an air quality model run which demonstrates that the unit(s) has not caused an exceedence of the NAAQS must be kept on-site for the life of the ERP emergency or non-emergency engine or turbine.

4.5.3.3 Copies of the certificates and documents from the manufacturer and supplier related to the certificates must be kept on-site for the life of the ERP emergency engine or turbine.

4.5.3.4 A monthly log of hours of operation, fuel type, heating value and sulfur content, a monthly calculation of the total hours operated in the previous 12 months, purchase orders, invoices, and other documents to substantiate information in the monthly log must be kept on-site for three years.



Emergency Engine and Turbine Requirements

Document Number: EHS-ENMG-SOP.01 Rev.4
Effective Date: July 14, 2014
Revision Date: July 14, 2019

4.5.3.5 NFPA 110 paragraph 8.4.1 mandates monthly tests under load for all emergency and standby systems, for a minimum of 30 minutes. For generators, paragraph 8.4.2 further specifies that a minimum load of either 30% of nameplate kW rating, or as otherwise sufficient to meet manufacturer recommended exhaust temperature, be provided during this test to address wet stacking.

4.5.3.6 Documentation must be kept stating that the unit(s) as designed and installed complies with the applicable emission limits for the first three years of operation when operated according to the manufacturer's instructions.

5.0 Key References

- 5.1 MA DEP Emergency Engine and Emergency Turbine Environmental Certification Workbook: www.mass.gov/dep/service/online/etwkbook.doc.
- 5.2 310 CMR 7.26(42) - Emergency Engine and Emergency Turbine ERP Regulations
- 5.3 NFPA 110-2009 Standard for Emergency and Standby Power Systems
- 5.4 EHS-ENMG-FRM-01 Rev.1 Emergency Engine and Emergency Turbine Form



Emergency Engine and Turbine Requirements

Document Number:
EHS-ENMG-SOP.01 Rev.4
Effective Date: July 14, 2014
Revision Date: July 14, 2019

Appendix A Stack Location and Design

The following summarizes and prioritizes the options for stack location and design when citing a new unit. Note that exhaust stacks must also comply with local building codes and National Fire Protection Association (NFPA) codes.

1. For new engines, consider locating the engine on the roof. For engines located on a roof inside an enclosure the stack should exit 5 feet above the enclosure for engines rated less than 300 kW and 10 feet above enclosure for engines rated 300 kW to 999 kW. For engines rated at 1 MW or more the stack should be 1.5 times the height/projected width of the building and taller than any nearby adjacent buildings.
2. For new engines located on the ground and relatively near other buildings, if possible, the stack should run up the side of the adjacent building and exit at least 5 feet above the roof if the engine is rated less than 300 kW (as a best management practice) or 10 feet for engines rated between 300 and 999 kW. Again, for engines rated at 1 MW or more, the stack height should be 1.5 times the height of the building and taller than any nearby adjacent buildings (otherwise and air quality model must be run demonstrating that the proposed stack meets the NAAQS).
3. For engines located on the ground and relatively near other buildings, if is not feasible to run the stack up the side of an adjacent building or there are no nearby adjacent buildings, then the stack should exit at least 5 feet above the roof of the enclosure if the engine is rated less than 300 kW (or 10 feet for engines rated between 300 and 999 kW. Again, for engines rated at 1 MW or more, the stack height should be 1.5 times the height of the nearby building and taller than any nearby adjacent buildings (otherwise and air quality model must be run demonstrating that the proposed stack meets the NAAQS). Again, if such a stack exits near operable windows, fresh air intakes or pedestrians all efforts should be taken to relocate the engine or identify an alternate stack configuration in order to minimize impacts to sensitive receptors. In addition, documentation must be maintained justifying the technical and economic reasons why the proposed configuration minimizes impacts to the maximum extent feasible. In some cases, operational limitations may be necessary to minimize impacts (e.g. limiting the duration and timing of preventative maintenance testing so that engines are run when nearby buildings are unoccupied). In cases where intakes or windows cannot be avoided entirely, MassDEP may request that a modeling analysis be conducted to confirm that the impacts do not violate air quality standards or pose a risk to building occupants.



Approved Rain Cap and Stack Configurations

Stack Height and Emission Dispersion (*verbatim from 310 CMR 7.26(42)(d)4.a.*)

- All engines or turbines shall utilize an exhaust stack that discharges so as to not cause a condition of air pollution (310 CMR 7.01(1)).
- Exhaust stacks shall be configured to discharge the combustion gases vertically and shall not be equipped with any part or device that restricts the vertical exhaust flow of the emitted combustion gases, including but not limited to rain protection devices “shanty caps” and “egg beaters”.
- Any emission impacts of exhaust stacks upon sensitive receptors including, but not limited to, people, windows and doors that open, and building fresh air intakes shall be minimized by employing good air pollution control engineering practices. Such practices include without limitation:
 - avoiding locations that may be subject to downwash of the exhaust; and
 - installing stack(s) of sufficient height in locations that will prevent and minimize flue gas impacts upon sensitive receptors.

Some of the below drawings and information taken from the “State of Vermont *AGENCY OF NATURAL RESOURCES* Department of Environmental Conservation Air Quality & Climate Division”

Examples of preferred, acceptable and unacceptable rain cap or stack configurations are shown below. Alternative configurations may be submitted to the Agency for approval prior to construction and installation.

Preferred Configurations

Offset Elbow Stack: The stack is offset using an elbow. The base of the elbow is enlarged at the bottom to create an opening that allows it to function as a drain. Rain runs down the inside wall of the stack and drains from the opening at the base of the elbow.

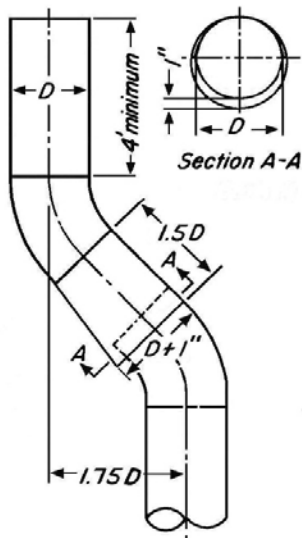



Offset Stack: The exhaust source is offset from the stack, and drainage features in the stack direct any water flow away from the exhaust source.

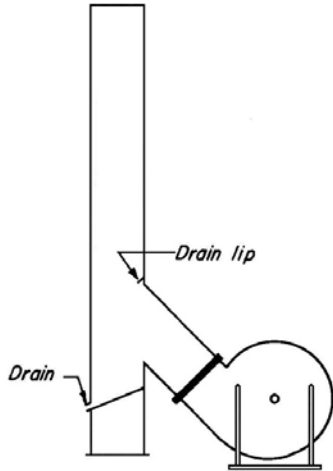

"Stack-in-a-Stack" Rain Cap: This configuration is based on the principle that rain falls at an angle. The inner stack is surrounded by an outer stack with space between the two. Rain runs down the inside wall of the outer stack, instead of down the inside wall of the inner stack.

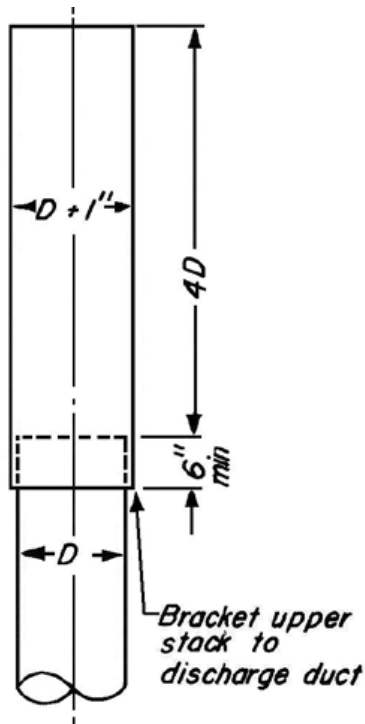



Emergency Engine and Turbine Requirements

Document Number:

EHS-ENMG-SOP.01 Rev.4

Effective Date: July 14, 2014

Revision Date: July 14, 2019

Hexagonal Rain Cap: This configuration diverts air around an internal wedge used to catch rain. The angle of the wedge should not exceed 60° to 75°. The stacks dimensions before and after remain the same. A hose is connected to the bottom of the wedge which drains the collected rain water.

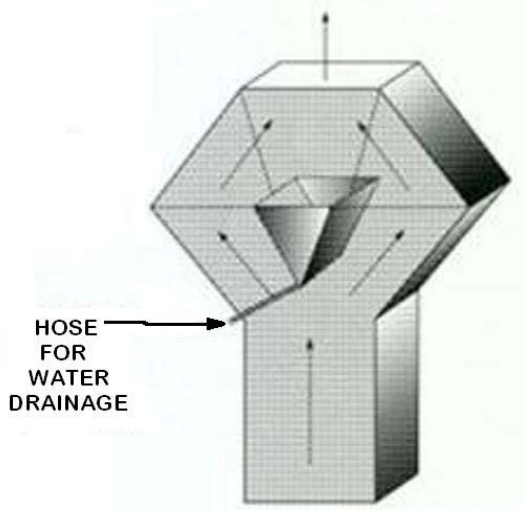

Acceptable Configurations

Approved by MADEP if in working order. "As long as it's counterweighted or otherwise opens with ANY flow/delta P, to meet the regulatory prohibition on restricting flow". EH&S has found that ice and snow may prohibit opening which is a violation.



Below link from GT Exhaust describes their counterweighted flapper caps. This is for discussion purposes only, not for recommendations of a vendor.

http://www.gtexhaust.com/docs/Installation%20Guide/Rain%20Caps%20Installation%20Guide_RevC.pdf



Unacceptable Configurations

Inverted Cone Rain Cap: Grating or brackets support the cone which is suspended above the stack opening. Note the maximum angle limitations. Drip ring improves effectiveness. This configuration slightly impedes dispersion and thus should only be used with taller stacks.

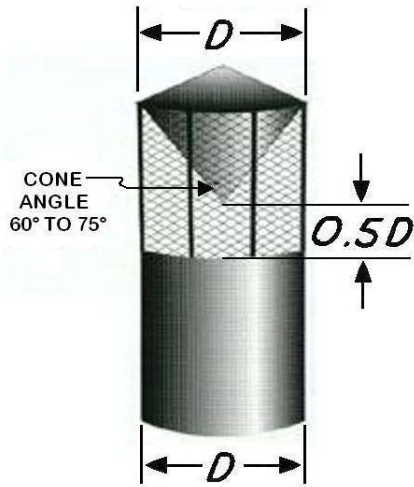

“Goose-Neck” Stack: Does not allow for unobstructed vertical flow.





Emergency Engine and Turbine Requirements

Document Number: EHS-ENMG-SOP.01 Rev.4
Effective Date: July 14, 2014
Revision Date: July 14, 2019

Hinged Rain Cap: A hinged flapper / damper is opened by the exhaust flow from the stack, and closes when the exhaust flow stops. Care must be taken to ensure continued proper operation. The flapper / damper on this type of cap may corrode, allowing the flapper / damper to stick open or closed. They may also freeze shut or be held closed by an accumulation of snow.



"Conventional" Rain Cap: Does not allow for unobstructed vertical flow.



Emergency Engine or Turbine Certification Form

Document Number:
EHS-ENMG-FRM-01 Rev.4
 Effective Date: July 14, 2014
 Revision Date: July 14, 2019

Please complete the following form for any new emergency engine or turbine installed on the University of Massachusetts Amherst campus or satellite locations. Should you have any questions about this program or the information requested below, please contact EH&S Dennis Gagnon: 545-5119, dgagnon@ehs.umass.edu or Terri Wolejko 577-3632 twolejko@ehs.umass.edu Please print the form once it is completed, attach the supplier statement and modeling if required and forward to Terri Wolejko EH&S Draper Hall.

Contact Information (Person Submitting Form)	
Name:	Phone:
Department:	Email:

Owner Information	
Department:	Unit Location:

Engine or Turbine Information	
Manufacturer of Unit	
Model	
Serial #	
UMass ID#	
Engine Rated Power Output (kW)	
EPA Certificate # for Unit (Oil Fired Engines Only)	
Date Installed	
Date Operation Commenced	

Genset Information	
Manufacturer of Unit	
Model	
Serial #	
UMass ID#	
Electrical Output (kW)	
Date Installed	
Date Operation Commenced	

Compliance Information	Yes	No
1) Is the new unit an emergency engine?		
2) Is the new unit an emergency turbine?		
3) Is the primary fuel to be burned natural gas?		

4) Is the primary fuel to be burned fuel oil?		
5) What is the sulfur content of the fuel oil (should be less than 15 ppm)		ppm
6) What is the size of the fuel tank?		gallons
7) What is the maximum run-time of the unit (fuel oil units only)?		hours
8a) Is the unit equipped with a non-turn back hour counter?		
8b) Is the unit equipped with a fuel meter capable of reading to a tenth of a gallon?		
9a) Is the exhaust stack configured to discharge the combustion gases vertically and not equipped with any part or device that restricts the vertical exhaust flow of the emitted combustion gases including, but not limited to, rain protection devices such as "shanty caps" and "egg beaters"?		
9b) Have you located the unit such as to minimize emission impacts upon sensitive receptors including, but not limited to, people, windows and doors that open, and building fresh air intakes by employing good air pollution control engineering practices? Such practices include avoiding locations that may be subject to down wash of exhaust and providing sufficient stack height to minimize flue gas impacts upon sensitive receptors.		
9c) If your unit has a power output rating less than 300 kilowatts is your stack height a minimum of five (5) feet above the facility rooftop or unit enclosure?		
9d) If your unit has a power output rating of 300 kilowatts or greater, but less than one megawatt, is your stack height a minimum of ten feet above the facility rooftop or unit enclosure?		
10a) If your unit has a rated power output of one megawatt or greater, is the height of your stack at least greater than 1.5 times the height of your building or lower than the height of a structure that is within 5L of the stack? (5L being five times the lesser of the height or maximum projected width of the structure.)		
10b) If 10a was answered "no" was an analysis using an EPA dispersion model performed to determine that the emissions will not cause a violation of the National Ambient Air Quality Standards.		
10c) If 10b was answered "yes"; did the analysis demonstrate that the stack emissions do not cause a violation of the National Ambient Air Quality Standards? (Attach a copy of the analysis to this certification form)		
11) Is your unit designed and located such that when operated, sound impacts upon sensitive receptors will be minimized and will not cause a condition of air pollution?		
12a) If your unit has a power output rating less than 300 kilowatts, is one additional circuit breaker installed for load bank testing rated to 100% of generator maximum output?		
12b) If your unit has a power output rating of 300 kilowatts or greater, is the unit equipped with built in load banks?		

Supplier Statement

For **emergency engines burning fuel oil**, please attach the statement from the supplier that the engine has been issued a Certificate of Conformity by the Administrator of the Environmental Protection Agency pursuant to 40 CFR 89.105 as in effect October 23, 1998, for the applicable emission limitations at the time of installation and is capable of compliance with the emission limitations for the first three years of operations.

For **emergency engines burning natural gas**, please attach the statement from the supplier that the engine meets the applicable non-road emission limitations that will satisfy the Certificate of Conformity requirement at the time of installation and is capable of compliance with emission limitation for the first three years of operation.

For **emergency turbines using any fuel**, please attach the statement that the unit meets the emission limitation for NOx (0.60 pounds per MW-hour).

For emergency engines and standby generators, please attach a statement that the generator set complies with NFPA 110 paragraph 7.13.4.3, that a two hour full load test was performed on-site.